



OPERATORS MANUAL

Covering Models

Superaxe	WS150-9
Superaxe	WS3150
Superaxe	WS4150
Superaxe	WS400
Superaxe	WS450

**PROUDLY
AUSTRALIAN
OWNED & MADE**

Manufactured & Distributed by
Burdurs Lane Enterprises Pty Ltd T/as
Whitlands Engineering
Ph: (03) 5729 7577
Fax: (03) 5729 7636
Email: superaxe@superaxe.com.au
A.C.N. NO. 106 741 084

CONTENTS

	PAGE NO
1. Limitations of use.....	2
2. Safety Precautions for Operator.....	3
3. Operator Training.....	4
4. Splitting Tips and Techniques.....	8
5. Inspection Schedule.....	9
6. Maintenance.....	10
6.1 Greasing	10
6.2 Engine	10
6.3 Hydraulics	10
6.4 Bolts	11
6.5 Blade.....	11
6.6 Spare Parts	11
7. Starting Up.....	11
8. Remote Powered Units.....	11
9. Towing /Tyres.....	12
10. Slinging.....	12
11. Storage.....	12
12. Decals.....	13
13. Troubleshooting	14
14. Specifications.....	15
15. Elevator Supplement.....	16
16. Warranty.....	18
17. Assembly Instructions.....	19
18. Risk Assessment.....	21

The MODEL NUMBER and SERIAL NUMBER and VIN number are stamped on identification plate on the hitch of your Woodsplitter. Please quote these numbers when ordering spare parts, or seeking information about the machine.

MODEL NO. _____

SERIAL NO. _____

PURCHASE DATE. _____

1. LIMITATIONS OF USE

Congratulations on choosing a Superaxe to split your firewood.

Due to the diverse nature of wood (easy, hard, knotty, straight/twisted grain, long/short, large/small blocks, dry, green stringy brittle etc.) splitting it by any mechanical hydraulic means can be an inherently dangerous and challenging job.

The Superaxe are easy and safe machines to operate. Even if you have operated similar machines to the Superaxe before, you must read, study and understand this manual before operating the machine. The manual is stored in the labelled receptacle fixed to the machine.

This manual contains important information that will instruct you in the correct training procedure, the necessary safety precautions, the operation and care of your machine. The risk assessment will alert you to dangers you may be exposed to whilst operating this machine.

TO ALL OPERATORS

You must read and understand this manual and risk assessment. Doing this is the first and most important step in becoming a competent operator. The next step is the gaining of experience by implementing safe, careful and responsible work practices. If available an experienced operator should assist in instructing new operators in Superaxe operation.

GUARD AGAINST ACCIDENTS

The Superaxe with 2 handed controls are very safe machines to operate. However due to the exposed blade and associated blocks being able to inflict cutting/crushing injuries accidents will be more likely to happen to untrained, inexperienced and/or complacent operators.

In particular if:

- Co-ordination is impaired (alcohol/drugs/fatigue)
- If distraction to the operator occurs
- If operating under performance based pressure

It is up to the operator to be aware of the potential dangers at all times and to work the machine with the due care it deserves.

It is your duty as a Superaxe owner to give suitable instruction to any new operator of your machine, teaching them safe and proper operating procedure. Also, be sure new operators are given the opportunity to study this manual before using the machine.

If ownership of this machine changes this manual should accompany the machine.

If this Manual is lost, please contact the manufacturer for a free replacement.



2. SAFETY PRECAUTIONS **FOR OPERATOR**

BE CAREFUL!

IMPROPER, UNSAFE OR RECKLESS USE OF THIS MACHINE COULD RESULT IN SEVERE PERSONAL INJURY TO THE OPERATOR OR BYSTANDERS

Please note the following points.

- **READ** and understand the Operator's Manual and machine operation decals, so that you can become familiar with the operation of the machine before operating it.
- **DO NOT** operate this machine if you are affected by fatigue or if your co-ordination is impaired or if you are under the influence of Alcohol or Drugs.
- **ALWAYS** wear Personal Protective Equipment (PPE) including but not limited to boots, gloves, hearing and eye protection and appropriate safety clothing when operating your wood splitter.
- **ALWAYS** keep your eyes on the moving blade and **NEVER** allow yourself to become distracted from the operation of the machine. If distraction occurs, **STOP** and deal with the distraction.
- **THIS** is a one operator machine. Never allow bystanders to interfere in the operation.
- **KEEP** the table and ground around the wood splitter clear of wood and debris. It is particularly important that the area where the operator stands is clear and level and free of tripping hazards.
- **DO NOT** allow children and untrained adults and bystanders to operate the machine and keep children and animals away while operating machine.
- **ALWAYS** be sure that the block is sitting firmly on the table before operating the blade.
- **BE AWARE** that if the Block Lifter capacity is exceeded the machine may tip up on one wheel or cause damage to the lifting frame.
- **DISCONNECT** hydraulic lines (remote powered units) or stop the power pack engine before attempting cleaning, maintenance or adjustment.
- **DO NOT** tamper with or modify any parts of the machine. If the machine has been found to be tampered with or modified – stop using it and have the machine rendered un-usable by an authorised person, (eg owner, hirer, qualified repairer) until the necessary repairs have been carried out.
- **CHECK** that safety decals are legible and in place. (See page 13)
- **READ** and understand the Risk Assessment in the rear section of this manual so you are fully aware of any possible dangers you may be exposed to while operating this machine.

3. OPERATOR TRAINING

ALL WOODSPLITTERS OPERATION

- Read and understand limitations of use and safety precautions for operation (previous page)
- Select a clear level site in a well ventilated or outdoor area
- Ensure machine is firmly chocked or hooked to tow vehicle
- Operator to be wearing appropriate Personal Protective Equipment (PPE)
- ie ear & eye protection, gloves, boots etc.
- Read engine manufacturers operating and maintenance instruction manual
- Check engine oil / fill with unleaded petrol.
- Start engine – for inexperienced operators run at ½ throttle, this slows the operation and allows new operators to become familiar with the machine more easily. For experienced operators run at ¾ - full throttle.
- Familiarise yourself with the two-handed controls. Push both levers down together to bring blade down. Lift both levers up together to bring blade up.
- If fitted with an auto return valve, the levers will unlock to neutral at the top of the return stroke.
- **WS400/450** – If fitted, a leg control can be used to bring blade up only.
- **WS150** - Remove R-clip securing block lifter in the up right travelling position, and fold to horizontal position. Release block lifter latch holding block lifter in the horizontal position and drop frame to ground level. Roll block on to block lifter frame and activate blade operating levers to lift frame. When block lifter catch has engaged in latch (frame is held in horizontal plane) the block can be moved onto table for splitting. **WS150** lifting capacity 150KG
- **WS400/450/3150-4150** - Lift the block lifter operating lever on the left-hand side of the machine to extend the block lifter ram out from under the table. Release the block lifter frame by removing the retaining R Clip, fold the frame over and connect the end of the ram to the frame using the pin attached to the block lifter frame by a short chain. Once connected, the frame can be lowered to the ground by pushing the lever down. A block can now be rolled onto the frame. Lift log lifter operating lever up to raise the frame. Lifting Capacity 200KG
- Damage caused by exceeding block lifter capacity is not covered by warranty.
- Position block on table, push backwards against post and select splitting line. Be sure the block sits squarely on the table and will not slip when the blade contacts it.
- **ALL MACHINES** - Operate blade levers down simultaneously to split the block

OPERATOR TRAINING cont.

- Move blade levers up simultaneously to retract the blade. If fitted with an auto return valve, the levers will unlock to neutral at the top of the return stroke. The return stroke can be halted by tapping the two levers downwards.
- **WS400/450** – If leg control is fitted - pull leg control back to retract blade
- Always release control when blade reaches the end of its' stroke
- Move timber to position for next cut etc. etc.
- If the splitter fails to split the block and the block is jammed on the blade, remove the block with a suitable mallet, re-position the block to an easier split position and try again.



CAUTION.

- DO NOT cut wood across the grain
- DO NOT split wood that won't sit firmly on the table
- BE AWARE that this is a very powerful machine. When splitting very tough brittle wood, pressure build up in the ram can cause sudden breakages or movements of the block – keep hands well away from block at all times.
- Always make sure that the area that the lifting frame operates in is clear of obstructions and that bystanders are kept well away.
- Be sure your feet are clear when lowering the block lifter frame.
- BE AWARE that exceeding block lifter capacity will tip the machine up on one wheel. Take extra care when lifting large heavy blocks.
- Do not leave the machine unattended while the engine is running.
- Shut off engine and allow to cool before re-fuelling.

TRANSPORT / TOWING

WS150

Fold log lifter frame up against post and secure with R clip
Ensure axe ram is fully retracted into cylinder

WS400/450/3150/4150

Remove ram pin and retract log lifter ram under table
Fold log lifter frame up against post and secure with R clip
Ensure axe ram is fully retracted into cylinder

REFER TO PAGE 12 FOR MORE DETAILS

SUPERAXE **WS400/450** OPERATION

The Superaxe works on the leverage principal. It develops enormous cutting force close to the pivot point of the blade and less force at the tip of the blade. The edge of the sharpened blade should contact the face of the block close to the post. This is the area of greatest splitting power. **To get the best performance from the Superaxe the blocks should be cut into even lengths to suit the blade height setting of the Woodsplitter or the blade height setting altered to suit the average length of timber.** (See Page 7)

The axe has 4 positions of height adjustment, which will cater for 9", 12" 15" 18" blocks.

TO CHANGE THE AXE HEIGHT- (18mm spanner or shifter required)

1. Set axe in a horizontal position and turn engine off.
2. Remove main pivot pin and raise or lower axe and replace pin. (Wear hand protection)
3. Remove lower ram pivot pin and raise or lower ram and replace pin. Be sure ram and axe pin holes correspond (See below)

See below Fig 1. for pin positions as per yellow sticker on machine

FIG. 1

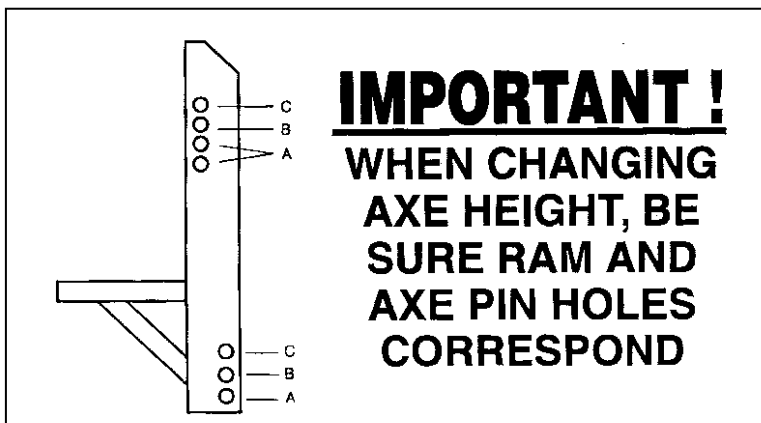
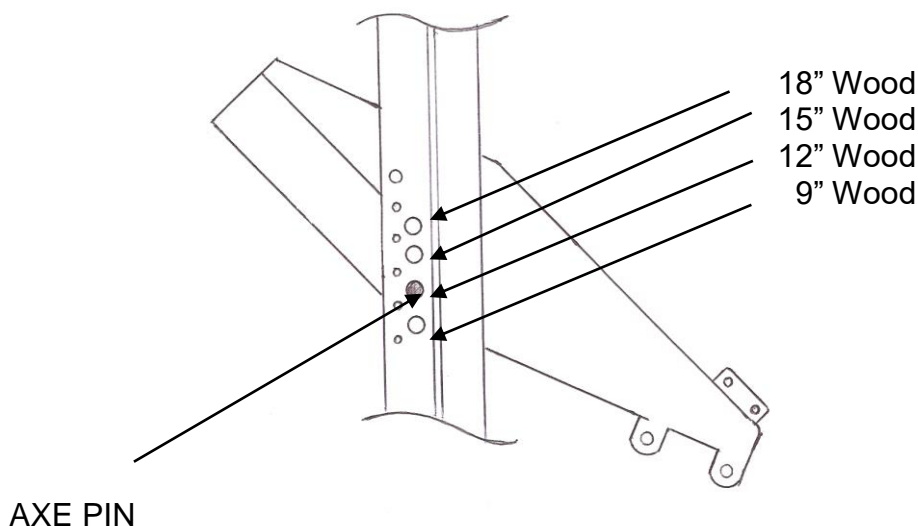

FIG. 2- AXE HEIGHT ADJUSTMENT



SUPERAXE WS400/450 OPERATION

CUTTING YOUR TIMBER TO AN EVEN LENGTH AND SETTING THE AXE ACCORDINGLY WILL ENABLE YOU TO GET THE BEST PERFORMANCE OUT OF YOUR SUPER-AXE.

FIG. 3
Optimum timber
Length for axe
Position



Corner of Block
contacts axe in
this area of the
blade

Gives
maximum
splitting
force

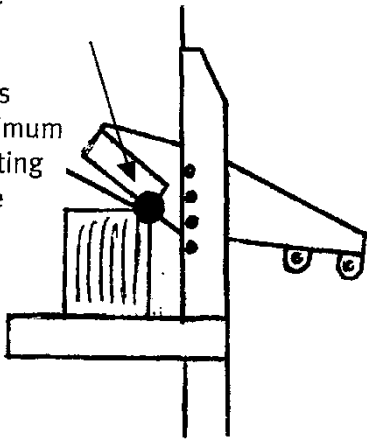

FIG. 4
Move axe up
or cut timber
shorter



Tip of blade contacts
wood first

Gives
minimum
splitting
force

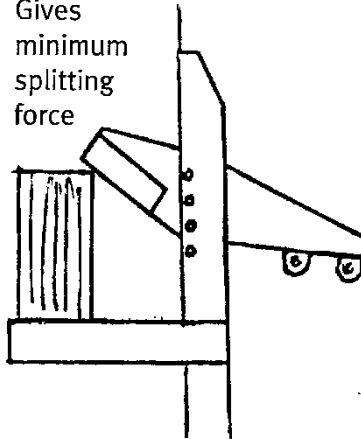

FIG. 5
Move axe down
or cut timber
longer



Tip of blade contacts
wood first

Gives
minimum
splitting
force

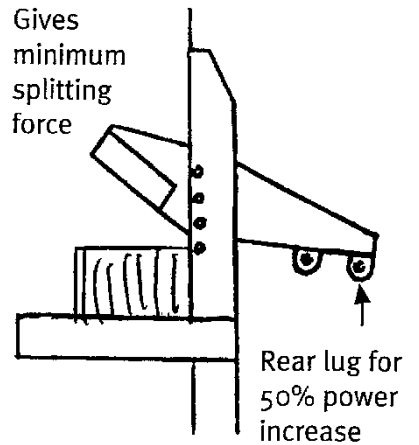
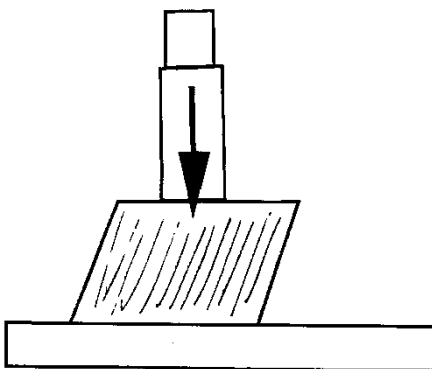
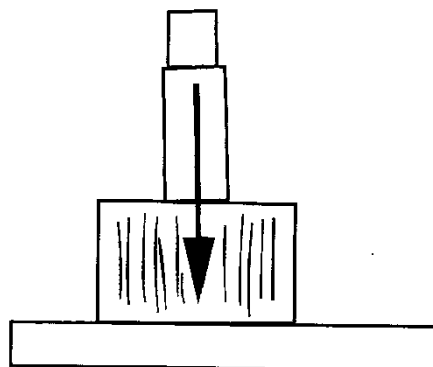

FIG. 6
INCORRECT



DO NO CUT WOOD
ACROSS OR AGAINST THE
GRAIN

CORRECT



ALWAYS CUT WOOD
WITH THE GRAIN

4. SPLITTING TIPS & TECHNIQUES

ALL MACHINES

- It is advisable if you are learning how to operate the machine to run the engine at approximately ½ throttle. This slows the operation speed and enables new operators to become familiar with the machine more easily.
- Always position the block so that the blade will follow the grain of the wood. Do not try to cut the wood across the grain (See Fig. 6, Page 7)
- The efficiency of the machine can be increased by doing multiple cuts (i.e. cutting 2 pieces at once)
- When splitting very tough wood, split along crack lines and take smaller bites.
- When splitting large blocks, work from outside of block ie. back it off
- When splitting small blocks use the block lifter frame held in the up position as an extension table to store a quantity of blocks ready to split.
- To make sliding heavy blocks across table easier, keep the table lubricated with silicon spray. i.e. Armour All or similar

WS400/450

- For consistent efficient operation, cutting your timber to an even length and setting the axe accordingly will enable you to get the best performance out of your Super Axe.
- Be sure that smaller awkward blocks engage the grate in the centre of the table. The block will grip it under pressure and prevent it slipping
- When splitting very tough wood move the top of the hydraulic ram to the end position on the axe. This position is slower but gives 50% more splitting power.
- If splitting very short tough wood, use a piece of 2" or 3" timber as a pad under the block to lift it up. This enables the power at the base of the axe to be used more efficiently.

YOUR DUTY OF CARE

It is your duty as a Superaxe owner to give suitable instruction to any new operator of your machine, teaching them safe and proper operating procedure. Also, be sure new operators are given the opportunity to study this manual before using the machine.

5. INSPECTION SCHEDULE & PRE OPERATION CHECKLIST

ALL MACHINES

Regular inspection of the following items will ensure that any problems are found and can be rectified promptly.

CHECK FOR	OK	NEEDS ATT.
Hand lever operation OK Decals fitted and legible Oil leaks / condition of hoses Loose / missing bolts Bent / broken / missing parts Regular greasing and engine maintenance Tyre condition and pressure Oil levels - engine and hydraulics		

See Page 10 "Maintenance" for more information

6. MAINTENANCE

Superaxe Wood splitters require very little maintenance to keep them operating reliably. Regular attention to the following points will ensure trouble free operation. NOTE: Always stop engine or disconnect remote power source before attempting any maintenance.

6.1 LUBRICATION

WS150/3150/4150

The blade slide surfaces need regular lubrication. A squeeze bottle chain and bar oil are supplied with and stored on the machine for this purpose. We recommend a squeeze of oil on the slide surfaces as required or every couple of hours of operation. If machine is operated without adequate lubrication damage to slide surfaces may occur. (Damage of this nature is not covered by warranty).

WS400/450

The main axe pivot and axe ram pivots should be greased every four hours of machine operation.

6.2 ENGINE

ALL MACHINES - The engine uses Unleaded Petrol and 30 grade oil in its crank case. Always check oil before starting. Change oil after 5 hours use (break in) and thereafter every 100 hours or annually.

The owners' manual for the petrol engine on the power pack is enclosed. Please refer to it for further operating and maintenance instructions for the engine

6.3 HYDRAULICS

CAUTION – Take care – Oil may be under high pressure when engine is running.

WS150/3150/4150

All hydraulic hoses fitted to your Woodsplitter are double wire rated. The large hoses are ¾” and have ¾ BSP female ends on them, the small ones are ¼” & ⅜” with JIC ends on them.

WS400/450

All hydraulic hoses fitted to your Woodsplitter are double wire rated, are either ⅜” or ½” and have ¾” JIC female ends on them.

ALL MACHINES

The hoses and fittings should be checked for tightness and leaks regularly. If a leak is found, stop engine or remote power unit immediately and attend to the leak. Render the machine unusable, until machine is repaired, always check hydraulic oil level after doing maintenance on the hydraulic system and top up if required.

The hydraulic oil system is filled with Grade 46 hydraulic oil. The oil level should not drop below 2” (50mm) below the top of the oil tank as indicated by the oil level sticker. Check the level occasionally by unscrewing the filler breather cap with a 27mm spanner or shifter and using a suitable dipstick to check the level.

6. MAINTENANCE cont

The hydraulic oil should be changed every 1000 hours of operation. The oil filter must also be changed at the same time. Remove the large suction hose between the tank and the pump and allow the oil to drain completely. Remove the two hoses from the ram and drain. Replace the hoses and refill the oil tank with new oil.

The oil filter on the power pack is a 10-micron Prince (FA10) Spin On. It is available from most hydraulic parts supplier or from Whitlands Engineering.

6.4 BOLTS

All bolts and pins on the Superaxe Woodsplitter should be checked for tightness regularly.

6.5 BLADE

All Machines - The blade edge is hardened spring steel and should never require sharpening.

6.6 SPARE PARTS

For all your spare parts requirements contact the supplier of your Superaxe Woodsplitter. For engine spares, see your local engine dealer

WS400/450

The pivoting blade is fitted with 2 bushes, which are replaceable if they become worn. Contact the supplier of the unit for replacements.

7. STARTING UP

Australian delivery machines are filled with both the correct grades and amounts of engine and hydraulic oil. The engine has been pre- run and the hydraulic system tested. The machine has been greased and only needs filling with the correct grade of petrol for operation to commence. Refer to engine manual for run in procedure.

8. REMOTE POWERED UNITS

All remote powered Superaxe woodsplitters are fitted with Australian Standard ½” hydraulic quick coupler tips. When the woodsplitter is connected to a remote hydraulic outlet or a PTO power pack the engine speed/flow control of the tractor/bobcat etc should be set giving: -

- (a) For machines controlled with a single lever the ram travel speed should not exceed 60mm/sec (ram extending)
- (b) For machines fitted with 2 handed controls the ram travel speed should not exceed 120mm/sec (ram extending).

8. REMOTE POWERED CONT.

This is the fastest speed that the Woodsplitter should be operated at to maintain proper control over the machine. If a John Deere tractor with closed centre hydraulics is to be used, the valve on the splitter will need to be converted from open centre to closed centre operation. Contact the Woodsplitter manufacturer for details.

9. TOWING/TYRES

ALL MODELS

Only woodsplitters that have a VIN plate fitted and are registered can legally be towed on public roads.

All models of these woodsplitters are suitable to be towed under most conditions, but extra care must be taken when travelling on rough roads and towing speed altered accordingly. The tyres should be kept at 20 psi and the wheel nuts should be checked occasionally. If regular or long-distance towing of the Woodsplitter is anticipated, the tyres can be let down to 15 psi to reduce bouncing.

BEFORE TOWING CHECK:

- That your woodsplitter complies with the trailer registration and towing laws in your state.
- Turn petrol off
- Machine connected properly to tow ball and R clip inserted
- Safety chain connected to tow vehicle
- Block lifter folded up and secured properly
- Hydraulic rams are fully retracted
- Jockey Wheel folded up or removed
- Lights plugged in and tested
- Observe 80 kph as the maximum speed limit for towing this trailer

10. SLINGING

All models can be lifted safely, slinging from the top of the post. Be sure that approved lifting devices are used.

11. STORAGE

We recommend that you follow these guidelines for long term machine storage:

- Retract hydraulic ram/s
- Turn petrol off
- Turn engine to compression stroke (all valves closed)
- Store under cover or cover engine to protect from weather
- Follow inspection schedule after bringing machine out of storage

12. SAFETY & MAINTENANCE DECALS

IDENTIFICATION



SAFETY

**OPERATORS
MANUAL
&
SAFETY
PROCEDURES
INSIDE TUBE**



**BEFORE OPERATING THIS
MACHINE**

Read and understand the Operator's Manual before using this machine. A person who has not read and understood the Operators Manual is not qualified to operate this machine. If the Manual is not available to read, do not operate the machine. Contact the supplier of the machine immediately for a replacement manual.



**BLOCK LIFTER
CAPACITY
150KG**

WS150

**BLOCK LIFTER
CAPACITY
200KG**

**WS3150- 4150
WS400-450**

OPERATIONAL



WS400/450

**KNEE CONTROL
PULL BACK
FOR AXE RETURN**

MAXIMUM TOWING SPEED

80 KPH



MAINTENANCE

WS400/450



WS150/3150/4150

**GREASE
SLIDE
REGULARLY**

HYDRAULIC OIL LEVEL

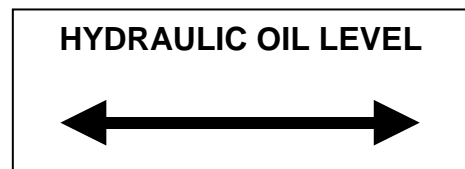

13. TROUBLE SHOOTING

PROBLEM	SYMPTOM	REMEDY
<p>ENGINE</p> <p>Engine won't start</p> <p>Engine won't run properly or stalls easily in normal operation</p>	<p>Switch off</p> <p>Low oil/petrol</p> <p>Flooded</p> <p>Choke off</p> <p>Choke on</p> <p>Dirty air cleaner</p> <p>Dirty fuel/spark plug</p> <p>Relief valve setting too high</p>	<p>Turn on</p> <p>Check</p> <p>Dry out</p> <p>Switch on</p> <p>Switch off</p> <p>Clean</p> <p>Clean/replace</p> <p>Consult manufacturer</p>
Consult you engine dealer if further diagnosis, service or repair is required		

<p>HYDRAULICS</p> <p>Engine runs but axe won't move</p>	<p>Hydraulic oil low</p> <p>Sus. Pump/drive condition</p> <p>Broken valve lever</p> <p>Control lever/s damaged</p> <p>Ram damaged</p>	<p>Top up oil</p> <p>Test/repair/replace</p> <p>Replace</p> <p>Repair</p> <p>Repair</p>
<p>Lack of splitting power / speed</p>	<p>Low oil</p> <p>Suspect pump</p> <p>Valve not fully opened by hand control</p> <p>Relief valve set too low</p> <p>Engine performance suspect</p> <p>Ram seals worn</p> <p>Machine operating on a steep angle</p>	<p>Top up oil</p> <p>Test/repair/replace</p> <p>Repair hand control</p> <p>Adjust</p> <p>Service/repair engine</p> <p>Replace</p> <p>Operate on level ground</p>
<p>Oil leaking from filler breather</p>	<p>Oil tank over full</p> <p>Machine operating on a steep angle</p>	<p>Drain some oil</p> <p>Operate on level ground</p>
For more detailed information or spare parts, contact the manufacturers		

14. SPECIFICATIONS

SUPERAXE						
ITEM	WS150	WS3150	WS3150	WS4150	WS400	WS450
ENGINE	Honda GX270	Honda GX270	Honda GX390	Vanguard	Honda GX390	Vanguard
	9 hp	9 hp	13 hp	18 hp	13 hp	18 hp
PUMP 2 STAGE	12/58 lpm	14/65 lpm	23/65 lpm	45/88 lpm		
PUMP 1 STAGE					30 lpm	44 lpm
MAX PRESSURE	3100 psi	3100 psi	3100 psi	3100 psi	3000 psi	3000 psi
RAM (AUS MADE)	4" X 18"	4" X 18"	4" X 18"	4 1/2" x 18"	3" X 16"	3" X 16"
SPLITTING FORCE	21 ton	21 ton	21 ton	< 26 ton	< 40 ton	< 40 ton
CYCLE TIME	8 sec	7 sec	7 sec	5.5 sec	6 sec	4.5 sec
MAX LOG LENGTH	18"	18"	18 "	18 "	18 "	18 "
HYD HOSES- 5000PSI DOUBLE WIRE	3/4"	3/4"	3/4"	3/4"	1/2"	1/2"
BLOCK LIFTER CAPACITY	150 kg	200 kg	200 kg	200 kg	200 kg	200 kg
WHEELS	155 x 13"	185 X 14"	185 X 14"	185 X 14"	185 X 14"	185 X 14"
HUBS	HIGH SPEED	HIGH SPEED	HIGH SPEED	HIGH SPEED	HIGH SPEED	HIGH SPEED
TOW COUPLING	50 mm	50 mm	50 mm	50 mm	50 mm	50 mm
JOCKEY WHEEL	8"	8"	8"	8"	8"	8"
LENGTH	2400 mm	2400 mm	2400 mm	2600 mm	2400 mm	2400 mm
WIDTH	1450 mm	1500 mm	1500 mm	1500 mm	1500 mm	1500 mm
HEIGHT	1700 mm	1700 mm	1700 mm	1700 mm	1700 mm	1700 mm
WEIGHT	450 kg	500 kg	550 kg	400 kg	450 kg	500 kg

15. ELEVATOR

The elevator when extended is 3.6m long. It is designed to operate at a maximum of 40° where it will comfortably load into a truck with sides 3.0m from the ground. It will easily handle the maximum output of the Woodsplitter. For travelling the elevator folds in half and sits neatly and compactly on the Woodsplitter. Folding/unfolding takes approximately 2 minutes and a brake winch is used to make this operation safe.

The Elevator is hydraulically driven off the splitter's hydraulic system and does not affect the performance of the axe. It has a convenient control lever located to the right side of the blade hand controls and the system is protected from overload (from accidental jamming) by a relief valve. Care must be taken when the elevator is in the extended position. (See Caution below)



CAUTION Regardless of whether the elevator is in the operating position or you are folding or unfolding it, keep yourself and others well clear especially from underneath the elevator. Never move the machine with the elevator in the extended position

Unfolding Procedure (See Page 17)

1. Extend stabilizer leg and adjust wheel to suit ground level.
2. Loosen cable 3-4 turns and hook into eye in centre hinge joint in elevator.
3. Pull out to a vertical position.
4. Lower elevator so roller is on the ground.
5. Roll top section out and lower elevator to unfolded position with winch. (A clear, level place makes this easier)
6. Unhook cable from centre position and re-hook onto end position. Lift elevator to horizontal position
7. Remove long pin from under chain and replace on top of chain.
8. Remove roller from end and using the same long pin, attach rubber flap to lower end.
9. Winch up to operating height.

Folding Procedure (See Page 17)

1. Stop elevator chain so that 2 cleats are positioned opposite of each other at the base of the elevator. This ensures that there will not be cleats in the way when folding the elevator up.
2. Put Log lifter in travelling position.
3. Lower elevator to horizontal – Remove pin from rubber flap and using same pin, fit roller to top end.
4. Fit long pin in centre of elevator, under chain and check again to see that cleats are positioned opposite of each other at the base of the elevator. (Step 1)
5. Lower to ground level, unhook cable from top end and re-hook into eye in centre.
6. Winch up to vertical position.
7. Push in so elevator sits against stop on post.
8. Unhook cable from centre hinge joint and hook to lifting loop on the end.
9. Tighten winch to hold elevator in travelling position.
10. Lift wheel and retract stabilizer leg to travelling position.

Lubrication and Maintenance

- Grease bearing sparingly, 1 pump of grease every 50 hours of operation.
- Adjust chains evenly to maintain 150-200mm hanging down in the centre of chain.
- The hydraulic system is maintenance free.
- The winch is maintenance free.
- Lubricate chains regularly with chain lube.

15. ELEVATOR – Unfolding procedure

Folding Procedure is a reversal of these steps.

NOTE check position of cleats before folding –
See instructions Page 16 (1)

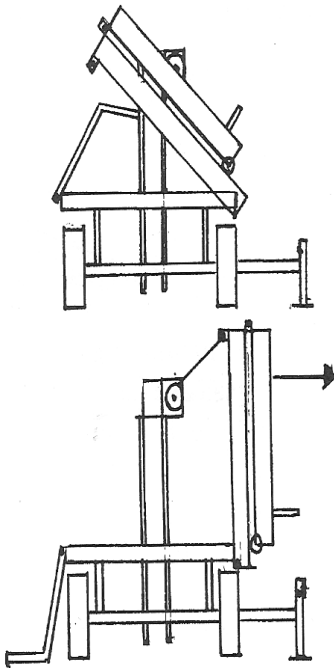

1. Extend stabilizer leg and adjust wheel to suit ground level.

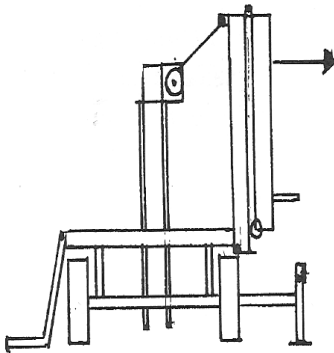

2. Loosen cable 3-4 turns and hook into eye in centre hinge joint in elevator.
3. Pull out to a vertical position. Elevator will now be supported by winch cable.

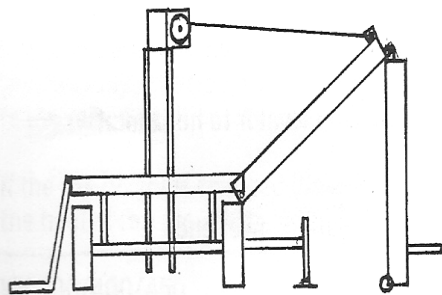

4. Lower elevator so roller is on the ground.

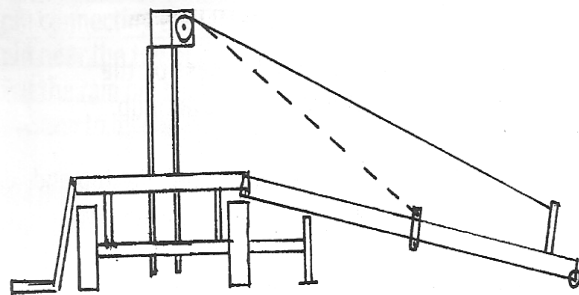

5. Roll top section out and lower elevator to unfolded position with winch.

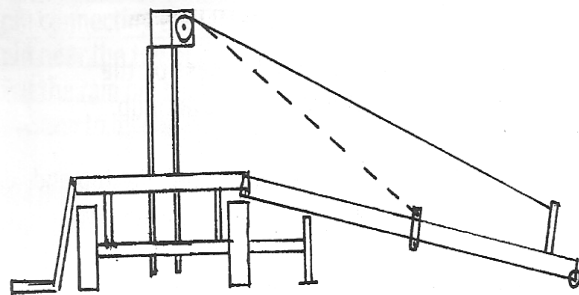

6. Unhook cable from centre position and rehook onto end position. Lift elevator to horizontal position

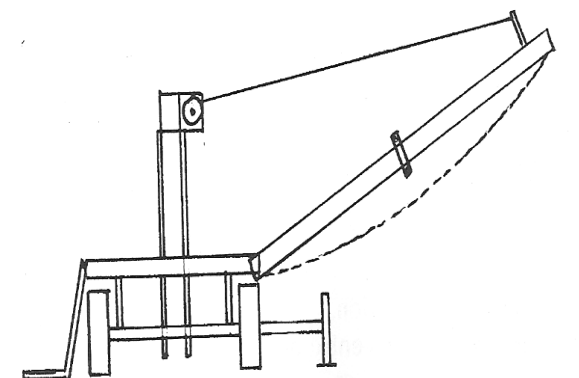

7. Remove long pin from under chain and replace on top of chain.

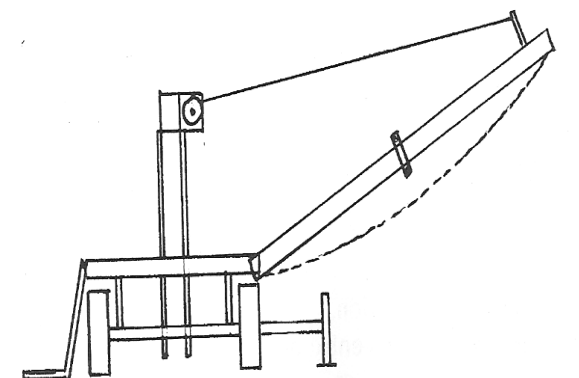

8. Remove roller from end and using the same long pin, attach rubber flap to lower end. Winch up to operating height.

16. WARRANTY

THIS WARRANTY IS EXPRESSLY CONDITIONED ON THE PURCHASER'S USE OF THE PRODUCT CONFORMING TO THE INSTRUCTIONS CONTAINED WITHIN THIS MANUAL

WARRANTY DESCRIPTION

Whitlands Engineering warrants the original purchaser of each new wood splitter to be free from defects in material and workmanship under normal use and service for a period of **two years** from the date of the initial sale and delivery.

WHITLANDS ENGINEERING WARRANTY CONDITIONS

Whitlands Engineering's obligation under this warranty is limited to replacement of any defective part or material, and normal labour, per flat rate schedule. During such period, this warranty excludes any obligation by Whitlands Engineering for the cost of transportation or any other cost arising out of such replacement.

The warranty will be voided if the product is damaged by accident, or by unreasonable use, negligence, improper service or other cause not arising out of defects in the materials or workmanship. Also, any part that fails due to the lack of lubrication as outlined in the Parts and Service Manual is not covered under the standard warranty.

WHITLANDS ENGINEERING will not repair the product or be responsible for any damages or injury to persons or property resulting from any attempt by the purchaser or by unauthorised persons or service personnel, to repair, adjust, assemble or otherwise tamper with the product or its controls or components

No authority is provided by the manufacturer to in any way modify, tamper or alter this unit without the expressed written authority from Whitlands Engineering

Authorised warranty repairs by the purchaser or approved third party need to be carried out only after consultation with Whitlands Engineering

No representative, agent or dealer for Whitlands Engineering is authorised to in any way modify, expand or extend this warranty

Whitlands Engineering reserves the right to introduce operational modifications to new models of its woodsplitting products without any obligation to retrofit previous models with these new features

WARRANTY EXCLUSIONS

Excluded from this warranty are all the components not manufactured by Whitlands Engineering. These items are covered only by standard warranties offered by their respective manufacturers and are not under warranty by Whitlands Engineering. This warranty excludes any obligation by Whitlands for loss of product down time or any other incidental or consequential damage incurred at any time.

NO ONE IS AUTHORISED TO ALTER OR TAMPER WITH THIS MACHINE WITHOUT THE EXPRESSED WRITTEN PERMISSION FROM THE MANUFACTURER.

17. ASSEMBLY INSTRUCTIONS

AVOID PERSONAL STRAIN.

This machine and all its parts are very heavy. A suitable device will be needed to lift the machine off the pallet before fitting the wheels. A lifting point is provided at the top of the post for lifting or slinging. Other parts are also heavy and help may be required to unpack the parts from the machine and to maneuver into their correct position. Please follow these instructions in the correct order to safely assemble this machine.



Basic spanner/socket sets are required for assembly incl., 13,17,18,19 & 21mm sizes. The assembly/bolt kit is inside the box packed inside the two wheels strapped onto the table.

17. SUPER-AXE – WS400/450 **SUPER-AXE – WS3150/4150**

CAUTION: Do not attempt to start or turn the engine over until the Power Pack unit has been correctly installed. Failure to do so may result in loss of oil and/or damage to the pump.

1. **Unpack** the Wood splitter from the pallet. Remove main frame from the pallet with a suitable lifting device.
2. **While the frame is raised**, Fit the A-Frame hitch to the main frame using 4 M12 x 40 bolts and Nyloc nuts.
3. Fit tow coupling with 3 x M12 x 30 bolts and Nyloc nuts
4. Fit jockey wheel using the 2 x U bolts provided.
5. Fit the wheels using 10-wheel nuts & 21mm wheel brace, **then lower unit to the ground**
6. If supplied, fit leg control hoop to leg lever pivot arm– 400/450 only.
7. Re-fit Hands Clear sticker plate right way up
8. Fit block lifter frame (if supplied) with 2 x M12 x 75 bolts and Nyloc nuts & r-clips
9. For machines fitted with a power pack, fit the engine/tank assembly to the A-frame hitch using 4 x M10 x 25 bolts and Nyloc nuts.
10. Connect short hose from pump – valve P (Supply hose).
11. Connect long hose from valve T – filter (Return hose).
12. Check all bolts/nuts/hoses for tightness.
13. Fill the engine with unleaded fuel and machine will be ready to run.

NOTE

Your Woodsplitter is shipped with both engine and hydraulic oil reservoirs full of the correct new oils. Your Woodsplitter has also been tested and run in our factory, and checked for leaks and malfunctions. When connecting the hoses, a small quantity of oil may leak from open fittings. Unless there is a major spill the oil tank will not need topping up.

For machines without power packs, your Woodsplitter can now be connected to a tractor or remote supply and operated. Connect supply line to Pressure outlet and return line to dump outlet. See Page 11 for further instructions.

Once assembled, read and understand manual before operating machine.

AVOID PERSONAL STRAIN.

This machine and all its parts are very heavy. A suitable device will be needed to lift the machine off the pallet before fitting the wheels. A lifting point is provided at the top of the post for lifting or slinging. Other parts are also heavy and help may be required to unpack the parts from the machine and to maneuver into their correct position. Please follow these instructions in the correct order to safely assemble this machine.



Basic spanner/socket sets are required for assembly incl., 13,17,18,19 & 21mm sizes. The assembly/bolt kit is inside the box packed inside the two wheels strapped onto the table.

SUPER-AXE – WS150

CAUTION:

1. Place machine and pallet firmly on level ground
2. Unfasten and remove the Log Lifter frame, hitch & draw bar, wheels, engine and kit box containing fasteners, bolts etc.
3. Fit Log lifter to table with (2) M10 x 65mm bolts & nyloc nuts.
4. Cut cable tie holding pump to pallet and position to front and centre of draw bar
5. Unbolt ties holding draw bar frame to pallet, position draw bar extension to this frame using (4) M12 x 40mm and nyloc nuts, tighten firmly.
6. Fit engine to draw bar frame. Fasten to frame with (4) M8 x 40 bolts, washers and nyloc nuts, tighten firmly.
7. Fit rubber spider gear to coupling on engine crankshaft.
8. Slide pump and coupling to engine coupling and ensure that couplings and rubber spider gear mesh correctly.
9. Bolt pump and bell housing assembly to engine using (4) 3/8 x 1" bolts & spring washer.
10. Fit orange inspection guard to pump housing.
11. Fit tow coupling to draw bar using (3) M12 x 30mm bolts and nyloc nuts.
12. Unfasten tie straps holding axle to pallet & using an appropriate lifting device lift machine off pallet and then fit wheels to hubs using (10) wheel nuts (in kit).
13. Fit jockey wheel using 2U bolts provided.
14. Lower to ground, check and tighten all bolts and nuts.
15. Fill the engine with unleaded fuel and machine will be ready to run.

NOTE

Your Woodsplitter is shipped with both engine and hydraulic oil reservoirs full of the correct new oils. Your Woodsplitter has also been tested and run in our factory, and checked for leaks and malfunctions. When connecting the hoses, a small quantity of oil may leak from open fittings. Unless there is a major spill the oil tank will not need topping up.

For machines without power packs, your Woodsplitter can now be connected to a tractor or remote supply and operated. Connect supply line to Pressure outlet and return line to dump outlet. See Page 11 for further instructions.

Once assembled, read and understand manual before operating machine.

18. SUPERAXE WOODSPLITTERS RISK ASSESSMENT

HAZARD	DANGERS YOU MAY BE EXPOSED TO	LEVEL OF DANGER	POSSIBILITY OF PERSONAL INJURY	CONSEQUENCES IF INJURY OCCURS	MEASURES IN PLACE TO CONTROL OR AVOID HAZARD
OPERATING THE MACHINE	Exposed and moving blade can create shear and jam points for hands and fingers against blade and block and table	VERY LOW	VERY LOW	Very little danger as both hands are occupied with operating levers in order to actuate blade	<p>Appropriate Personal Protective Equipment (PPE) to be worn</p> <p>Clear and definitive Safety Hazard sign at eye level in front of operator</p> <p>Machine is simple and uncomplicated to operate.</p> <p>Blade control is clearly and appropriately identified.</p> <p>The speed of travel of blade is relatively slow for distance travelled.</p> <p>When operating, co-ordination between hands, brain and eyes is easy, natural and uncomplicated.</p> <p>The neutral position of the operating levers is positive and easily located.</p> <p>Hands cannot be put in danger zone while operating blade levers</p> <p>Operator training and associated safety issues have been well addressed by administrative control in the operator's manual</p>
	Possible ejection of wood from under blade	LOW	LOW	Remote possibility of bruising, laceration to fingers, hands or stomach of operator	<p>Appropriate PPE to be worn</p> <p>Clear and definitive Safety Hazard sign at eye level in front of operator</p> <p>Responsibility for the safety of operator lies with the operator 's understanding of training procedures, administrative controls and attention and diligence to work practices</p>

	FATIGUE from overwork	MEDIUM	MEDIUM	Possibility of severe bruising, laceration squashing or amputation of fingers or hands.	Appropriate PPE to be worn Table is at optimum height so operator can work comfortably for long periods with an easy relaxed stance Do not continue to operate if fatigued. Operator training and associated safety issues have been well addressed by administrative control in the operator's manual
	Associated body strains	VERY LOW	VERY LOW	Remote possibility of body strain, soreness in arms or back	Block lifter addresses manual handling issues by lifting heavy blocks to table height. Table is at optimum height so operator can work comfortably for long periods with an easy relaxed stance. Machine is simple and uncomplicated to operate Work area is directly in front of operator so no reaching, stretching or excessive movements are required to operate the machine efficiently and effectively.
	Operators getting splinters in hand	VERY LOW	VERY LOW	Minor possibility of splinter stuck in hands or fingers	Appropriate PPE to be worn (Gloves)
	Tripping over blocks in work area	LOW	LOW	Minor possibility of bruises, sprains or fractures	Set up machine on level ground Operator to keep work area free from obstacles. i.e. practice good house-keeping
SUMMARY	Due to two handed controls, risk to the operator from the moving axe blade and associated blocks of timber is low. <u>We recommend that</u> the operator has read and understood training procedures, because the full responsibility for the safety of the operator lies with their understanding of the administrative controls (correct training and operation procedures) and their attention and diligence to their work practices.				

ENGINE	Noise	LOW	LOW	Hearing Loss	Appropriate PPE to be worn Hearing protection stickers fitted to the machine Engine meets noise emission standards.
	Hot exhaust	VERY LOW	VERY LOW	Burns to body parts	Operator not working in vicinity of exhaust
	Exhaust fumes	VERY LOW	VERY LOW	Nausea/fainting	Use in open air. Exhaust faces away from operator.
	Rotating Parts	NONE	NONE		All rotating parts covered prevents any contact with body parts
	Refuelling hot engine	LOW	MEDIUM	Burns to Hands or Body parts	Wait until engine cools down before re-fuelling. Avoid spilling petrol. Read engine manual Engine manual supplied with machine explains engine operating procedure and associated hazards more concisely.
SUMMARY	Engine poses no obvious risk to operator or bystanders				
HYDRAULICS	Contact with high pressure oil from burst hose	LOW	LOW	Operator's clothes and exposed skin in contact with oil	Appropriate PPE to be worn (Hearing & eye protection, boots, gloves, protective clothing) All new hydraulic components are used in the manufacture of Superaxe woodsplitters. All hydraulic hoses are double wire rated therefore giving plenty of margin for safety. All hoses are routed to eliminate any rubbing or kinking type damage. The individual relief valves on all machines are set at the factory and the system is tested for leaks at peak pressure.
	Burns from contact with oil	VERY LOW	VERY LOW		It is the nature of this machine that the oil will not heat up enough to burn if contact is made with it.
	Rotating parts	NONE	NONE		All rotating parts are enclosed preventing any contact with body parts
SUMMARY	Hydraulic system poses no obvious risk to operator or bystanders+				

TOWING/ MANOUEVERING		VERY LOW	VERY LOW		<p>Approved cast 50mm coupling used rated at 2000kg.</p> <p>Jockey Wheel fitted to avoid lifting heavy hitch end and to make manoeuvring by hand easy.</p> <p>Pneumatic wheels fitted for safe towing and easy manoeuvring.</p> <p>Recommendations for towing in manual under towing section</p>
SUMMARY	Towing or manoeuvring the machine poses no obvious risk to operator, bystanders or other road users if guidelines in manual are followed.				
MAINTENANCE		NONE	NONE		<p>It is recommended in the Superaxe Woodsplitter manual that the engine is stopped or hydraulic lines disconnected before any maintenance is performed.</p> <p>Read and understand engine and operators manual before performing maintenance on the engine and machine</p> <p>Operator training and associated safety issues have been well addressed by administrative control in the operator's manual</p>
SUMMARY	Maintenance procedures pose no obvious threat to operator or bystanders. The machine is designed to be very simple to maintain with a minimum of tools and expertise required.				
CONSTRUCTION		VERY LOW	VERY LOW		<p>Many thousands of units in the field with a very, very high rate of customer satisfaction confirms that the machine is reliable, well engineered and constructed and poses no risk to the operator from it bending, breaking or becoming unusable.</p> <p>All new materials and components are used in its construction.</p> <p>A quality control checklist is done for each machine before it leaves the factory.</p>
SUMMARY	Construction poses no obvious risks to operator or bystanders				

Elevator (if fitted)	Machine becoming unstable with elevator in the raised position	LOW	LOW		Always set machine up on level ground and ensure machine is firmly chocked or hooked to tow vehicle. Always use stabiliser arm with adjustable wheel to stabilise machine
	Rotating chain can create jam points for fingers	MEDIUM	MEDIUM	Entanglement causing bruising, lacerations, squashing, amputation of fingers or hand	Rotating motor drive coupling is guarded. It is highly impractical to guard the underneath of the elevator where the chain is exposed. We recommend in the manual that you keep yourself and others well clear from the elevator at all times. Elevator control stop button is clearly and suitably signed and located conveniently beside the operator.
	Body strain when folding/unfolding elevator	VERY LOW	VERY LOW	Remote possibility of body strain, soreness in arms or back	Unfolding/folding procedure is easy, simple and effective. The manual has both written and pictorial descriptions of the folding/unfolding procedure. Brake winch is fitted for safe operation
	Elevator winch failing or cable breaking and elevator falling to ground	LOW	MEDIUM	Fractures, broken bones, serious injury or death	We recommend in the manual that you keep yourself and others well clear from the elevator at all times. Winch capacity well exceeds its lifting requirement Cable specifications well exceeds lifting requirement Brake winch fitted for safe operation Operator training and associated safety issues have been well addressed by administrative control in the operator's manual

RISK ASSESSMENT SUMMARY

The Superaxe Woodsplitters, when compared to others, are considered to be a very safe, efficient and effective machine. The innovative design features ensure that the arduous task of wood splitting is made as simple, productive and comfortable as possible.

This risk assessment gives you a realistic view of any dangers you may possibly encounter while splitting wood with this machine. **Do not forget** that splitting wood by any mechanical/hydraulic means can be an inherently dangerous job and that it is up to the operator to be aware of the potential dangers at all times and to work the machine with the due care the job deserves.