

MHP13/35

TRAILER MOUNTED BOOM LIFTS



- Safe and stable working height of up to 12.6m
- Heavy duty trailer mounted articulated boom lift
- Robust steel platform with two man capacity
- Easy to use outrigger/boom safety interlocks
- Ideal for a wide range of applications

 **snorkel**[™]
www.snorkellifts.com

TRAILER MOUNTED BOOM LIFTS

MHP13/35

DIMENSIONS MHP13/35

| | |
|--|---------------------|
| Max.height | 12.6m |
| Max. platform height (A) | 10.6m |
| Horizontal outreach | 5.6m at 6m |
| Platform size | 1.25m x 0.78m 1.07m |
| Outrigger footprint | 3.7m x 3.9m |
| Overall width (outriggers extended) | 3.95m |
| Overall width (outriggers retracted) (B) | 1.58m |
| Overall length (C) | 5.99m |
| Transport length (D) | 2.05m |

PERFORMANCE

| | |
|----------------------------------|---------------------|
| Platform capacity (with rotator) | 227kg |
| Max. wind speed | 12.5m/s |
| Levelling | auto |
| Turntable rotation | 540° non-continuous |
| Tyres | 185 R14 |
| Brakes | Hydraulic disc |
| Max. axle capacity | 1,750kg |
| Trailer tongue weight | 65kg |

POWER

| | |
|------------------|--------------------------------|
| Power source | Honda petrol engine 5.5hp |
| Hydraulic system | Proportional electro/hydraulic |

WEIGHT

| | |
|--------------|---------|
| Gross weight | 1,360kg |
|--------------|---------|

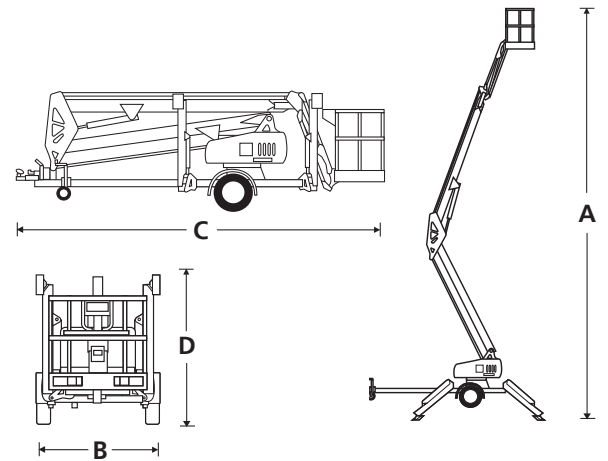

STANDARD FEATURES

- High strength steel boom and base construction
- Proportional speed control
- Heavy duty tow coupling
- Heavy duty jockey wheel
- Hydraulic disc brakes
- Reliable petrol engine
- Versatile jib boom (+70° to -70°)
- Articulating boom sections for 'up & over' reach
- 600V AC rated cable to platform
- Two man steel platform
- Automatic self-levelling stabilisers
- Outrigger/boom safety interlocks
- Lockable hinged covers
- Hour meter
- Lifting lugs
- Rotating basket mount
- Platform rotator
- Spare wheel

OPTIONS

- Flashing light
- 110/240V GFCI power to platform
- Diesel and bi/energy options

WORKING ENVELOPE

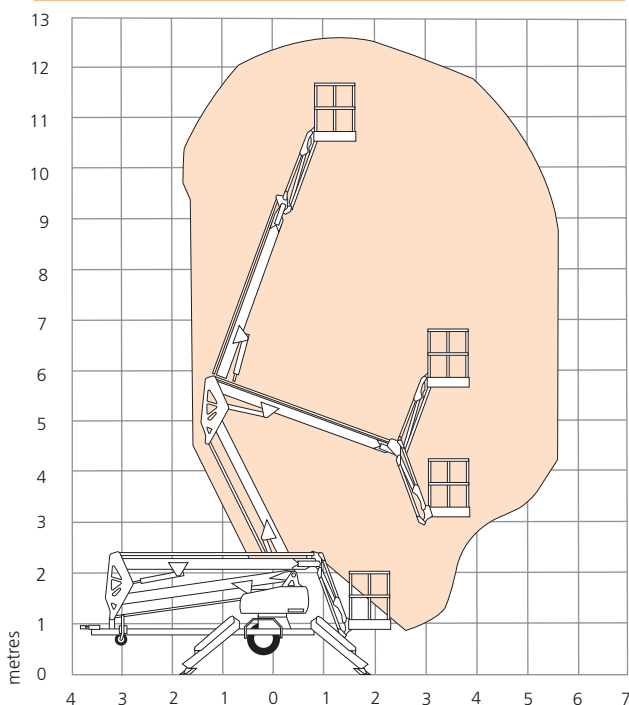

snorkel www.snorkellifts.com

Vigo Centre, Birtley Road,
Washington, Tyne & Wear,
NE38 9DA, U.K.

t: +44 (0) 845 1550 057
e: sales@snorkellifts.com