

Brushcutter Safety Manual

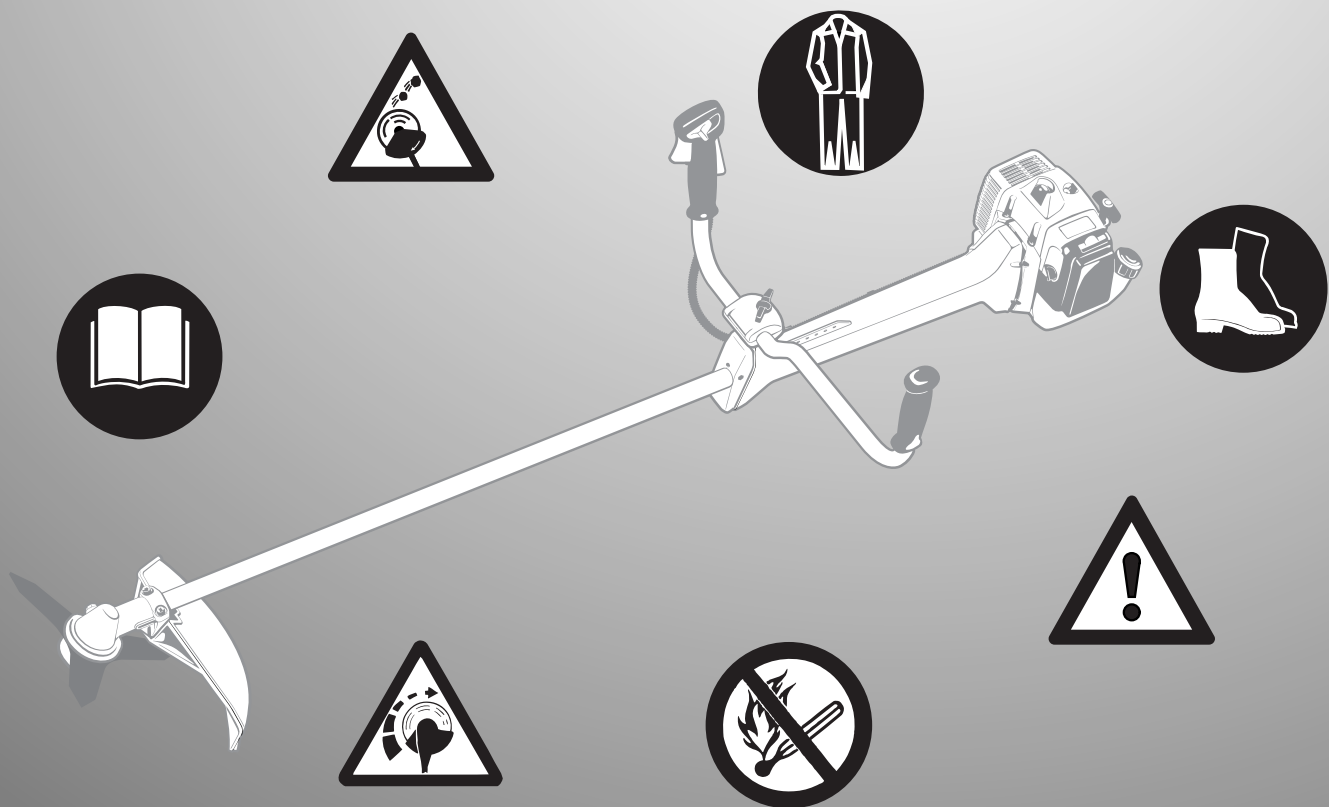

Contents



Warning!

Because a brushcutter is a high-speed cutting tool, some special safety precautions must be observed to reduce the risk of personal injury.

Careless or improper use may cause serious or even fatal injury.

To receive maximum performance and satisfaction from your STIHL brushcutter, it is important that you read and understand the maintenance and safety precautions before using your brushcutter. Contact your STIHL dealer or the STIHL distributor for your area if you do not understand any of the instructions in this manual.



Warning!

Before using a backpack brushcutter (FR 108), electric trimmer (FE 40, 55) or a direct drive string trimmer (FS 44), consult the owner's manual for the particular model for additional warnings and instructions.

Printed on chlorine-free paper

Printing inks contain vegetable oils,
paper is recyclable

© Andreas Stihl AG & Co. KG, 2003

0457 187 0121. M3. D2. Rei. Printed in Germany

Safety Precautions	3
Parts and Controls	14
Maintenance Chart	16

STIHL®

Safety Precautions



Because a brushcutter is a high-speed, fast-cutting power tool some **special safety precautions** must be observed in addition to those that generally apply when working with hand tools.



It is important that you read and understand the owner's manual before using your brushcutter for the first time. Keep it in a safe place for later reference. Non-observance of the following safety precautions may cause serious or even fatal injury.

Always observe local safety regulations, standards and ordinances.

If you have never used this brushcutter model before:

Have your STIHL dealer show you how to operate your brushcutter or attend a special course of training in brushcutter operation.

Minors should never be allowed to use a brushcutter.

Bystanders, especially children, and animals should not be allowed in the area where a brushcutter is in use.

The operator is responsible for avoiding injury to third parties and damage to their property.

Do not lend or rent your brushcutter without the owner's manual. Be sure that anyone using your blower understands the information contained in this manual.

You must be in good physical condition and mental health and not under the influence of any substance (drugs, alcohol) which might impair vision, dexterity or judgment.

Depending on the cutting tool fitted, use your brushcutter only for cutting soft green plants, wild growth, shrubs, scrub, bushes, small diameter trees and similar materials. To reduce the risk of personal injury, do not use your power tool for any other purpose.

Only attachments supplied by STIHL or expressly approved by STIHL for use with your specific model are authorized.

Other attachments must not be used because of the increased risk of accidents.

Never attempt to **modify** your power tool in any way since this can be extremely dangerous and result in serious or fatal injury. STIHL cannot accept any liability for personal injury or damage to property caused by modifications to the power tool or using attachments not approved by STIHL.

Clothing and Equipment

Wear proper protective clothing and equipment.



Clothing must be sturdy and snug-fitting, but allow complete freedom of movement - a STIHL safety coverall is recommended.

Avoid loose-fitting jackets, scarfs, neckties, jewelry, flared or cuffed pants or anything that could become caught on branches or brush. Secure hair so it is above shoulder level.



Wear steel-toed **safety boots** with non-slip soles.



Wear a **safety hard hat** for thinning work, in high scrub and where there is a danger of head injuries. To reduce the risk of injury to your eyes from thrown

objects, always wear **safety glasses** and a face shield.

Warning! A face shield alone does not provide adequate eye protection.

Wear hearing protection barriers (ear plugs or ear muffs).



Wear **heavy-duty, non-slip gloves**, preferably made of chrome leather.

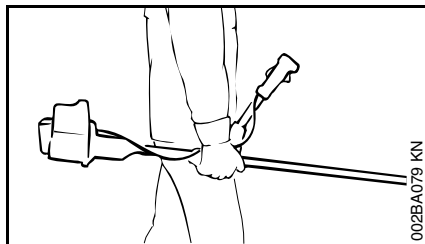

Transporting the Unit

Always turn off the engine. Carry the unit suspended from harness or properly balanced by the drive tube. If unit is carried while detached from the harness, cover the metal cutting tool with the transport guard to reduce the risk of accidental contact.

Transporting in a vehicle:
Properly secure your unit to prevent turnover, fuel spillage and damage.

When the unit is not in use (work break), put it down so that it does not endanger others.

Fueling

Always shut off the engine before refueling.



Gasoline is an extremely flammable fuel.

Do not smoke or bring any fire or flame near the fuel.

Do not fuel a hot engine – fuel may spill and cause a fire.

Remove the fuel filler cap on the unit carefully so as to allow any pressure build-up in the tank to release slowly.

Fuel your unit in well-ventilated areas, outdoors only. Wipe off any spilled fuel before starting and check for leakage. Take care not to get fuel on your clothing. If this happens, change immediately.



Unit vibrations can cause an improperly tightened fuel cap to loosen or come off and spill quantities of fuel. In order to reduce risk of fuel spillage and

fire, tighten fuel cap as firmly as possible.

Check for fuel leakage while refueling and during operation. If fuel leakage is found, do not start or run the engine until leak is fixed.

Before Starting

Check that your power tool is properly assembled and in good condition – refer to appropriate chapters in the owner's manual:

- Slide control / stop switch must move easily to **STOP** or 
- Smooth action of throttle trigger and throttle trigger interlock (where applicable) – throttle trigger must return automatically to idle position.
- Check that spark plug boot is secure – a loose boot may cause arcing that could ignite combustible fumes and cause a fire.
- Cutting tools and attachments: Check for correct and secure assembly and good condition.
- Never attempt to modify the controls or safety devices.
- Keep the handles dry and clean, free from oil and dirt, for safe control.

- Adjust harness and handle(s) to suit your height and reach. See chapter "Fitting the Harness – Balancing the Brushcutter".

To reduce the risk of accidents, never operate your power tool if it is damaged, improperly adjusted or not completely or securely assembled

Starting the Engine

Start the engine at least 3 meters (10 feet) from the fueling spot, outdoors only.

Place the unit on firm ground in an open area. Make sure you have good balance and secure footing. Hold the unit securely. The cutting tool must be clear of the ground and all other obstructions.

Your brushcutter is a one-person unit. Do not allow other persons within a radius of 15 meters (50 feet) of your own position – even when starting – to reduce the risk of injury from thrown objects or contact with the cutting tool.

Do not drop start the power tool. The correct starting procedure is described in your owner's manual.



Note that the cutting tool continues to rotate for a short period after you let go of the throttle trigger (flywheel effect).

Check idle speed: The cutting tool must not rotate when the engine is idling with the throttle trigger released.

To reduce the risk of fire, keep hot exhaust gases and hot muffler away from easily combustible materials (e.g. wood chips, bark, dry grass, fuel).

During Operation



Your power tool produces **toxic exhaust fumes** as soon as the engine is running. These fumes may be colorless and odorless. Never run the

engine indoors or in poorly ventilated locations.

To reduce the risk of serious or fatal injury from breathing toxic fumes, ensure proper ventilation when working in trenches, hollows or other confined locations.



To reduce risk of fire, **do not smoke** while operating or standing near your power tool. Note that combustible fuel vapor may escape from the fuel system.

Operate your power tool so that it produces a minimum of noise and emissions – do not run engine unnecessarily, accelerate the engine only for cutting.

The use of this machine may generate dust, vapor and smoke containing chemical substances. Such substances may cause serious injuries and health problems, i.e. respiratory diseases, cancer, birth defects or other reproductive harm.

If you are unfamiliar with the risks associated with dust, vapor and smoke emissions, ask your employer or the responsible authority to provide the relevant information.

Do not work alone – keep within calling distance of others in case help is needed.

If you get tired, take a break in good time.

General precautions:
Be particularly alert and cautious when wearing hearing protection because your ability to hear warnings (shouts, alarms, etc.) is restricted.

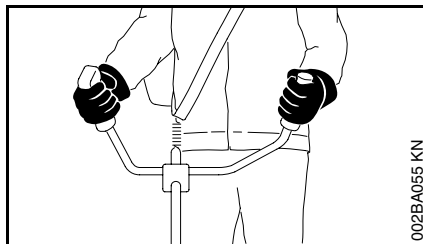

All handle versions:

Always hold the unit **firmly with both hands** on the handles. Make sure you have a firm and secure footing at all times.

Version with bike handle:

Right hand on control handle, left hand on left handle.

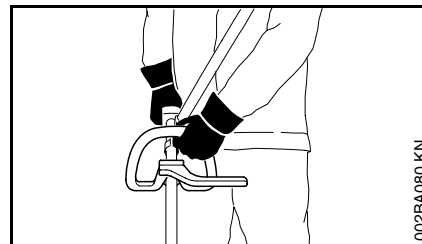

Versions with loop handle and loop handle with barrier bar:

Left hand on loop handle, right hand on control handle on drive tube.

Work calmly and carefully – in daylight conditions and only when visibility is good. Stay alert at all times so as not to endanger others.

Use your power tool only for the operations described in the owner's manual.

Do not operate using the starting throttle lock as you do not have control of the engine speed.



To reduce the risk of personal injury from thrown objects, never operate the unit without the proper deflector for the type of cutting tool being used.

When using nylon line heads:

Equip the standard deflector with the additional component specified in the owner's manual.

Operate only with nylon lines of the correct length. When the deflector and line limiter blade are properly mounted, the nylon lines are automatically trimmed to the correct length.

Using the unit with over-long nylon cutting lines increases the load on the engine and reduces its operating speed. This causes the clutch to slip continuously and results in overheating and damage to important components (e.g. clutch, polymer housing components). There is also a risk of injury from the cutting tool rotating while the engine is idling.

When using a **circular saw blade**, always fit the matching **stop**.

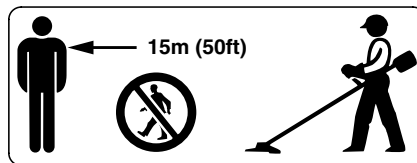

To reduce the risk of personal injury from thrown objects, ensure that bystanders are at least **15 meters (50 feet)** away.



Before cutting, inspect the area for stones, glass, pieces of metal or other solid objects which could damage the cutting tool or be thrown and cause

damage to property (e.g. parked vehicles, windows).

Special care must be taken when working in difficult, over-grown terrain.

When cutting high scrub, under bushes and hedges: Keep cutting tool at minimum height of 15 cm (6 in) to avoid harming small animals (e.g. hedgehogs).

When felling trees: Maintain a distance of at least two and a half tree lengths from the next felling site.

The correct **engine idle speed** is important to ensure that the cutting tool stops rotating when you let go of the throttle trigger.

Check and correct the idle speed adjustment regularly. If the cutting tool still rotates at idle speed, have your STIHL dealer make proper adjustments and repairs.

Take special care in slippery conditions – damp, snow, ice, on slopes, uneven ground, etc.

Watch out for hidden obstacles such as tree stumps, roots and ditches to avoid stumbling.

Before starting work, check the deflector and rider plate for damage or wear. Replace damaged parts. Never operate your unit with a damaged deflector or worn rider plate (lettering and arrows no longer visible).

Clean cutting tool mounting at regular intervals. If the cutting tool or deflector becomes clogged or stuck, always turn off the engine and make sure the cutting tool has stopped before cleaning.

Check the cutting tool at regular short intervals. If behavior of cutting tool changes, check it immediately, especially sharpness:

- Turn off the engine. Hold brushcutter firmly and press the cutting tool into the ground to bring it to a standstill.
- Check condition – look for cracks.
- Replace damaged or dull cutting tools immediately, even if they have only superficial cracks.

To reduce the risk of unintentional engine start and injury, always shut off the engine and remove the spark plug boot before replacing the cutting tool.

Sharpen metal cutting tools regularly as specified. Dull or improperly sharpened cutting edges can put a higher load on the cutting tool and increase the risk of it cracking or shattering.

Never repair damaged or cracked cutting tools by welding, straightening or modifying the shape. This may cause parts of the cutting tool to come off and result in serious or fatal injuries.

Always shut off the engine before leaving the unit unattended.

Vibrations

Prolonged use of the unit may result in vibration-induced circulation problems in the hands (whitefinger disease).

No general recommendation can be given for the length of usage because it depends on several factors.

The period of usage is prolonged by:

- Hand protection (wearing warm gloves).
- Operation with frequent breaks.

The period of usage is shortened by:

- Any personal tendency to suffer from poor circulation (symptoms: frequently cold fingers, itching).
- Low outside temperatures.
- Gripping force (a tight grip hinders circulation).

Continual and regular users should monitor closely the condition of their hands and fingers. If any of the above symptoms appear, seek medical advice.

Maintenance and repairs

Do not attempt any maintenance or repair work not described in your owner's manual. Have such work performed at your STIHL service shop only.

Never modify your power tool in any way as this could result in serious injury.

Always stop the engine and disconnect the spark plug boot before doing any maintenance or repair work or cleaning the machine.

Exception: Carburetor and idle adjustments.

Always clean dust and dirt off the machine after finishing work.

Do not service or store your unit near any fire or flame!

- Check fuel cap regularly for leaks.
- Use only a STIHL-approved spark plug (see Specifications) and make sure it is in good condition.
- Inspect ignition lead (insulation in good condition, secure connection).
- To reduce the risk of fire due to ignition outside the cylinder, move the stop switch to **STOP** or **I** before turning the engine over on the starter with the spark plug boot removed or the spark plug unscrewed.
- Check condition of muffler periodically.
- To avoid **risk of fire and hearing loss**, do not operate your unit if the muffler is damaged or missing.
- Never touch a hot muffler or burn will result.

Cutting Tools and Deflectors

For safety reasons only the cutting tools listed in this manual may be mounted to your brushcutter.

⚠ Warning!

Mowing heads may only be used on bike handle or loop handle brushcutters.

Grass cutting blades and brush knives (metal) may only be used on bike handle brushcutters or loop handle brushcutters with barrier bar.

Circular saw blades (metal) may only be used on bike handle brushcutters.

No other polymer or metal cutting tools may be used.

Always use the deflector and harness specified for your cutting tool: see "Approved Combinations of Cutting Tool, Deflector, Handle and Harness".

Handle cutting tools properly – only as described in this manual.

Symbols on Deflectors

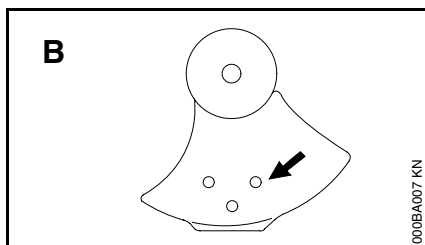
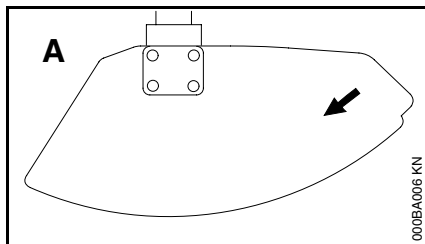

The **direction of rotation** of the cutting tool is indicated by an **arrow** on the deflector (**A**) for all mowing tools and the stop (**B**) for circular saw blades.

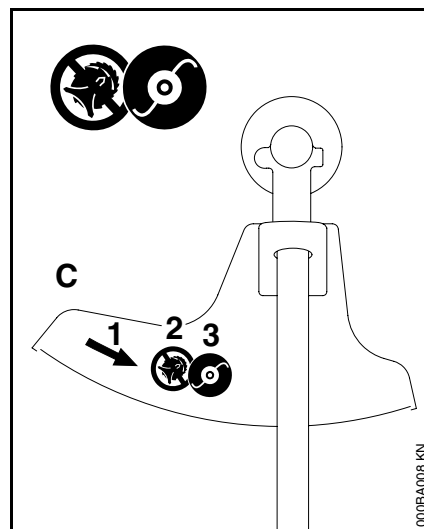

Symbols on deflector (**C**) for nylon line mowing heads only:

- 1 Arrow shows direction of rotation of cutting tool**
- 2 "Do not use metal cutting tools"**
- 3 "Use only nylon line mowing heads"**

Harness / Shoulder Strap

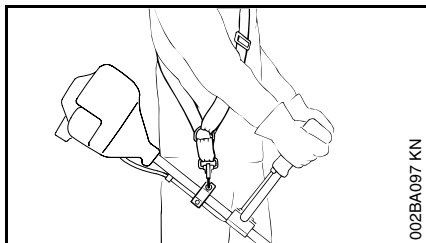

- Use a harness.
- With the engine running, attach the brushcutter to the harness.

In countries of the European Union (EU):

Grass cutting blades and brush knives must always be used in combination with a shoulder strap.

Circular saw blades must always be used in combination with a quick-release full harness.

Nylon Line Cutting Head

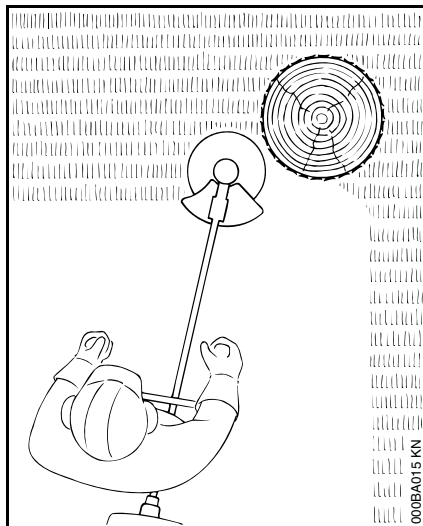

Nylon line achieves soft cut for edging and trimming around trees and fence posts – less risk of damaging tree bark.

- ⚠** To reduce the risk of serious injury, never use wire or metal-reinforced line or other material in place of the nylon cutting line.

STIHL PolyCut Cutting Head with Plastic Blades

The PolyCut is used for edging fields not bordered by posts, fences, trees or other obstacles.

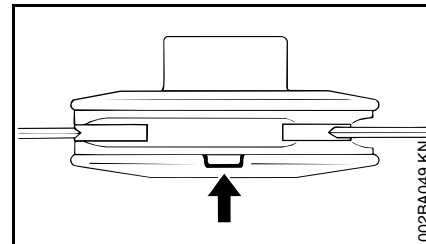

Check wear limit marks

If one of the marks on the PolyCut is worn through (arrow): To reduce the risk of injury from thrown parts, **stop using the head immediately**. Install a new one.

It is important to follow the maintenance instructions for the PolyCut cutting head.

Risk of kickout (blade thrust) with all metal cutting blades

When using metal cutting tools (grass cutting blade, brush knife, circular saw blade) there is a risk of kickout when the shaded area of the rotating blade comes into contact with a solid object like a tree trunk, branch, tree stump, rock or similar. The brushcutter is thrown to the right or to the rear.

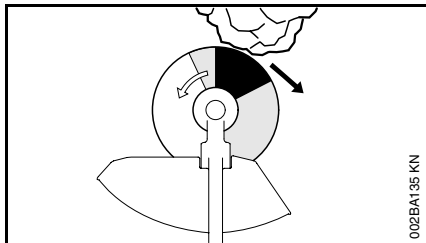

The **risk of kickout is greatest** when the **black area** of the rotating blade comes into contact with a solid object.

Cutting Blade

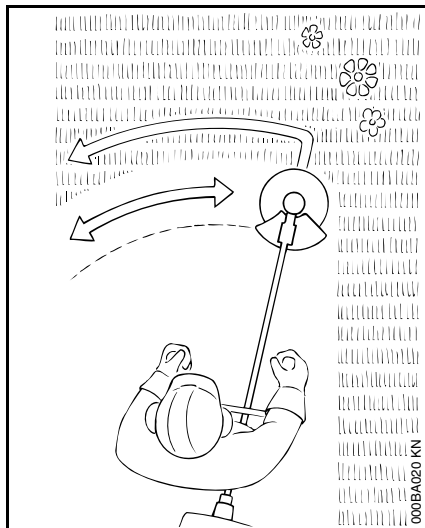

The cutting is suitable for all kinds of soft green plants and weeds. Use by sweeping the brushcutter an arc like a scythe.

Resharpener the cutting blade when it has dulled noticeably.

Brush Knife

Suitable for cutting matted grass, wild growth and scrub, thinning young stands with a maximum stem diameter of 2 cm (3/4"). To reduce the risk of personal injury, never attempt to cut thicker wood.

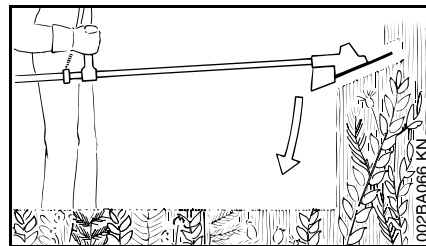

To cut wild growth and scrub, lower the brush knife down onto the growth to achieve shredding effect.

Exercise extreme caution when using this method of cutting. The higher the cutting tool is off the ground, the greater the risk of cuttings being thrown sideways.

Use the brushcutter like a scythe (sweep it to the right and left) at ground level when cutting grass and thinning young stands.

Warning! Improper use of a brush knife may cause it to crack, chip or shatter. Thrown parts may injure the operator or bystanders.

To reduce the risk of personal injury it is essential to take the following precautions:

- Avoid contact with hard or solid foreign objects such as stones, rocks or pieces of metal.
- Never cut wood or shrubs with a stem diameter of more than 2 cm (3/4”).
- Inspect the brush knife at regular short intervals for signs of damage. Do not continue working with a damaged brush knife.
- Resharpener the brush knife regularly (when it has dulled noticeably) and have it balanced if necessary (by STIHL dealer).

Circular Saw Blade

Circular saw blades are suitable for thinning brush and cutting small trees up to a diameter of **4 cm** (1 1/2 in).

Before starting the cut, accelerate the engine up to full throttle. Perform cut with uniform pressure.

Risk of kickout (blade thrust)

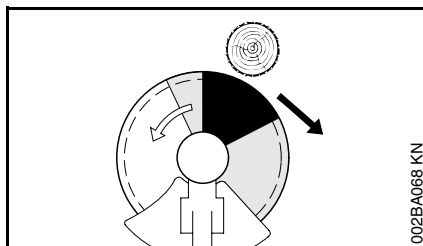

The risk of kickout is highest in the **black area** area of the blade: Do not use this area of the circular saw blade for cutting.

There is also a risk of kickout when using the **lighter shaded areas** of the blade: These areas of the blade should only be used by experienced operators with specialized training in the use and control of the brushcutter.

To reduce the risk of kickout, STIHL recommends that you always start the cut using the **non-shaded area** of the circular saw blade.

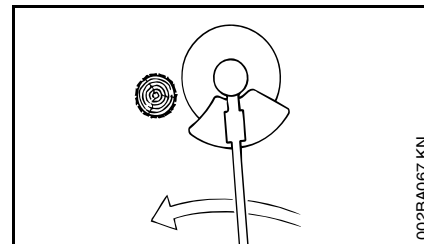

- ⚠** To reduce the risk of blade damage, avoid contact with stones and the ground. Resharpener the blade properly in good time – dull teeth may result in the blade cracking and shattering and causing serious injury.

Parts and Controls

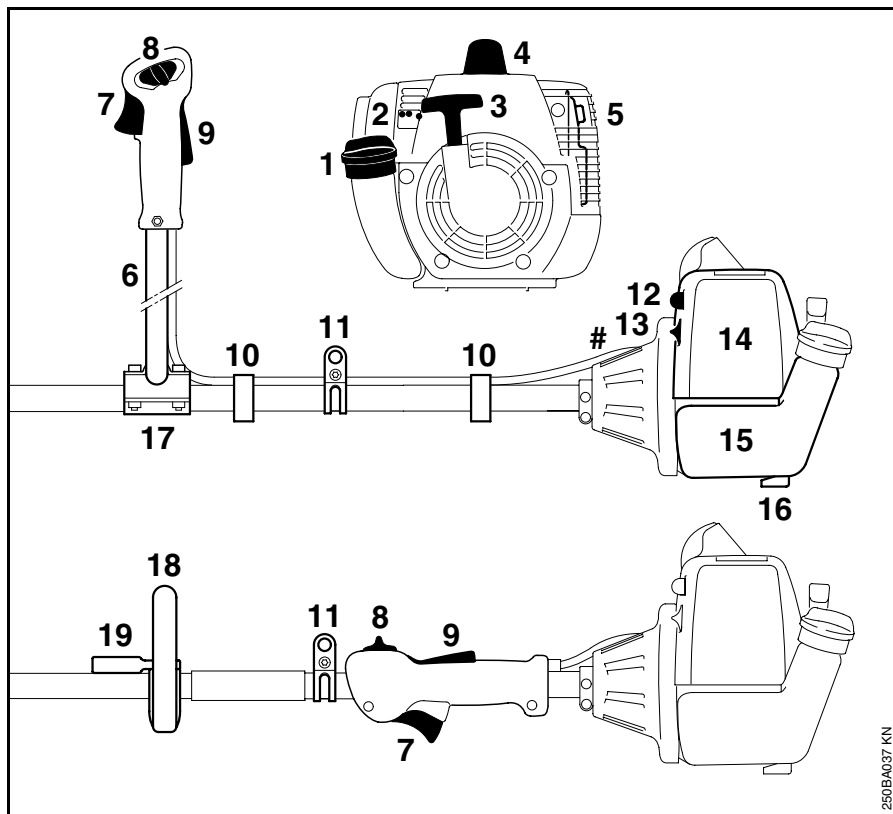

- 1 Fuel filler cap
 - 2 Carburetor adjusting screws
 - 3 Starter grip
 - 4 Spark plug boot
 - 5 Muffler (with spark arresting screen)
 - 6 Bike handle
 - 7 Throttle trigger
 - 8 Slide control
 - 9 Throttle trigger interlock
 - 10 Throttle cable retainer
 - 11 Carrying ring
 - 12 Fuel pump
 - 13 Choke knob
 - 14 Air filter cover
 - 15 Fuel tank
 - 16 Machine support
 - 17 Handle support
 - 18 Loop handle
 - 19 Barrier bar
- # Serial number

250BA037 KN

Part 2

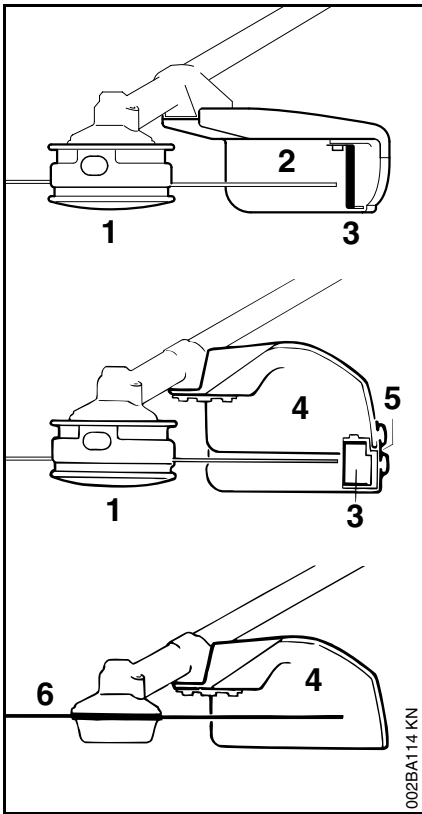

- 1 = Mowing head
- 2 = Deflector
(for mowing heads only)
- 3 = Line limiting blade
- 4 = Deflector with skirt
(for all cutting tools)
- 5 = Skirt
(for mowing heads)
- 6 = Metal cutting tool

Maintenance Chart

Please note: Different models may have different parts and controls.		before starting work	after finishing work or daily	after each refueling stop	weekly	monthly	every 12 months	if problem	if damaged	as required
Complete machine	Visual inspection (condition, leaks)	X		X						
	Clean		X							
Control handle	Check operation	X		X						
Air filter	Clean							X		X
	Replace								X	
Filter in fuel tank	Check							X		
	Replace						X		X	X
Fuel tank	Clean					X		X		X
Carburetor	Check idle adjustment – cutting tool must not turn	X		X						
	Readjust idle									X
Spark plug	Readjust electrode gap							X		
Cooling inletst	Inspect		X							
	Clean									X
Spark arresting screen in muffler	Inspect ¹⁾							X		X
All accessible screws and nuts (not adjusting screws)	Retighten									X
Cutting tool	Visual inspection	X		X						
	Replace								X	
	Sharpen metal cutting tool	X								X
	Check tightness of cutting tool	X		X						
Gearbox lubrication	Check				X					
	Top up									X
Antivibration system	Check ¹⁾							X		X

1) STIHL dealer